

COMPRESSED AIR BALL FLOAT TRAPS FA20 (Carbon Steel)

DESCRIPTION

The FA20 compressed air float trap series are specially designed for draining water from high pressure compressed air and gas lines. Usual applications include aftercoolers, separators and compressed air and gas mains.

An air balance pipe must be fitted, to allow the air trapped in the FA20 body to escape, avoiding obstructing the condensate flow.

MAIN FEATURES

Modulating discharge.
Unaffected by sudden or wide load and pressure changes.

OPTIONS: Equalizing and drain plug on body.
Lifting lever.

USE: Compressed air and non corrosive gases compatible with the construction.

AVAILABLE MODELS: FA20 – 21.

SIZES: 1/2" to 1", DN 15 to DN 25.

CONNECTIONS: Female threaded ISO 7 Rp.
Flanged EN1092-1 PN40 or ANSI B16.5 Class 150 lb or 300 lb.
Special flanges upon request.

INSTALLATION: Horizontal or vertical installation.



APPLICATION LIMITS	
Min. liquid specific weight	0,75 kg/dm ³
Maximum working diff. pressure	21 bar

CE MARKING – GROUP 2 (PED – European Directive)	
PN40	Category
1/2" to 1"; DN 15 to 25	SEP

BODY LIMITING CONDITIONS		
FLANGED PN40 / ANSI 300 lb *	FLANGED ANSI 150 lb**	RELATED TEMPERATURE
ALLOW. PRESS.	ALLOW. PRESS.	
37,1 bar	15,4 bar	100 °C
33,3 bar	13,8 bar	200 °C
30,4 bar	12,1 bar	250 °C
27,6 bar	10,2 bar	300 °C

PMO – Max. operating press. 21 bar;

TMO – Max. operating temp. 200 °C;

* According to EN1092-1:2018; ** According to EN1759-1:2004;
Body limiting conditions PN40 or below, depending on the type of connections adopted. Rating PN40 for thread, SW and BW.

FLOW RATE CAPACITY (kg/h)																
MODEL	SIZE	DIFFERENTIAL PRESSURE (bar)														
		0,5	1	1,5	2	3	4	6	7	8	9	10	12	14	16	21
FA20	1/2" to 1" DN 15 to 25	75	100	125	155	180	220	255	275	290	305	320	345	375	420	480

DIMENSIONS (mm)

SIZE	THREADED						PN16/40		ANSI 150 lb		ANSI 300 lb	
	A	B	C	D	H	WGT. (kg)	F	WGT. (kg)	F	WGT. (kg)	F	WGT. (kg)
1/2" – DN 15	95	178	23	128	1/4" NPT	5,2	150	6,7	150	6,2	150	7
3/4" – DN 20	95	178	23	128	1/4" NPT	5,2	150	7,4	150	6,6	150	8,2
1" – DN 25	95	178	23	128	1/4" NPT	5,2	160	7,8	160	7,4	160	9

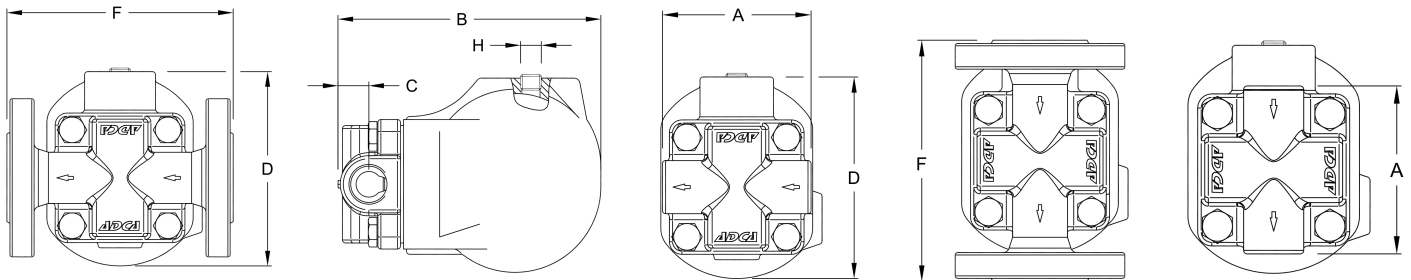

MATERIALS

POS. N°	DESIGNATION	MATERIAL
1	Body	GP240GH / 1.0619
2	Cover	GP240GH / 1.0619
3	* Gasket	Stainless steel / Graphite
4	* Seat	AISI 410 / 1.4006
5	* Valve	Viton
		AISI 440C / 1.4125
6	* Lever	AISI 304 / 1.4301
7	* Float	AISI 304 / 1.4301
8A	** Compression fitting	Stainless steel or Steel Fe/Zn
9	Bolts	Steel 8.8

* Available spare parts; ** Optional, against extra price;

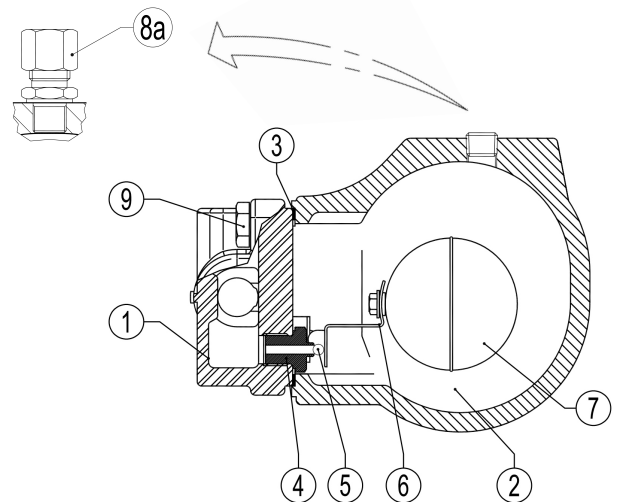

TYPICAL INSTALLATION

